

24" Electric Cooktop

500 Series – Black Frameless NEM5466UC



BOSCH
Invented for life



NEM5466UC
Black

The 24" electric cooktop, sleek in design, features optimal temperature control and is ideal for kitchens with a smaller footprint.

Features & Benefits

Precise temperature control for better cooking results.

Ceramic glass surface makes cooking and cleaning especially easy.

Residual heat indicator – warns if cooktop is warm or hot.

Push-to-turn control knobs.

Ideal for kitchens with a small footprint.

General Properties

Knob material Plastic

Element Performance

Power of Front Left heating element 1,850 W

Power of Back Left heating element 2,200 W

Power of Back Right heating element 1,200 W

Power of Front Right heating element 1,800 W

Element Size

Dimension of Front Left heating element 6"

Dimension of Back Left heating element 8"

Dimension of Back Right heating element 6"

Dimension of Front Right heating element 7"

Technical Details

Watts 7,100 W

Circuit breaker 30 A

Volts 208-240 V

Frequency 60 Hz

Plug type No plug

Energy source Electric

Dimensions & Weight

Overall appliance dimensions (HxWxD) 1/8" + 4 1/3" x 23" x 20 1/5"

Required cutout size (HxWxD) 4 1/3" x 22" x 19 1/4"

Minimum distance from counter front 2 1/4"

Minimum distance from rear wall 2"

Net weight 24 lbs

Accessories – Optional



HEZ390210
8" AutoChef® pan



HEZ390220
9" AutoChef® pan



HEZ390230
10" AutoChef® pan



For help and assistance with Bosch accessories please visit: www.bosch-eshop.com/eshop/bosch/us or call 1-800-944-2904 Mon-Fri 5am to 6pm PST Sat 6am to 3pm PST

Notes: All height, width and depth dimensions are shown in inches. BSH reserves the absolute and unrestricted right to change product materials and specifications, at any time, without notice. Consult the product's installation instructions for final dimensional data and other details prior to making cutout. Applicable product warranty can be found in accompanying product literature or you may contact your account manager for further details.

Warranties: Bosch warrants that the Product is free from defects in materials and workmanship for a period of three hundred and sixty-five (365) days from the date of purchase. The foregoing timeline begins to run upon the date of purchase, and shall not be stalled, tolled, extended, or suspended, for any reason whatsoever. This Product is also warranted to be free from cosmetic defects in material and workmanship (such as scratches of stainless steel, paint/porcelain blemishes, chip, dents, or other damage) to the finish of the Product, for a period of thirty (30) days from the date of purchase or closing date for new construction. This cosmetic warranty excludes slight color variations due to inherent differences in painted and porcelain parts, as well as differences caused by kitchen lighting, product location, or other similar factors. This cosmetic warranty specifically excludes any display, floor, "As Is", or "B" stock appliances.

For more information on our entire line of products, go to www.bosch-home.com/us or call 1-800-944-2904

© BSH Home Appliances Corporation. All rights reserved. Bosch is a registered trademark of Robert Bosch GmbH.

24" Electric Cooktop

500 Series – Black Frameless NEM5466UC



BOSCH
Invented for life

Installation Details

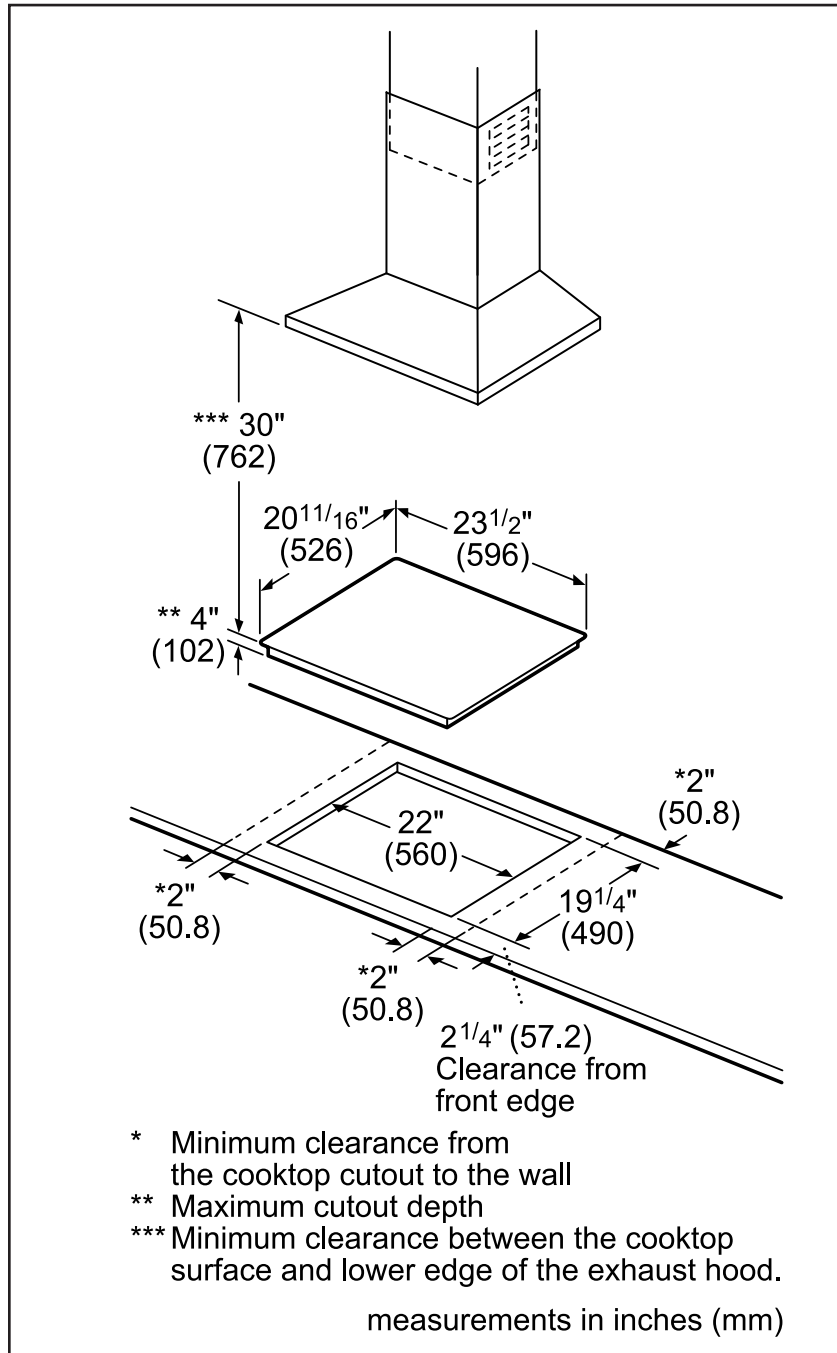

Installation above Wall Ovens

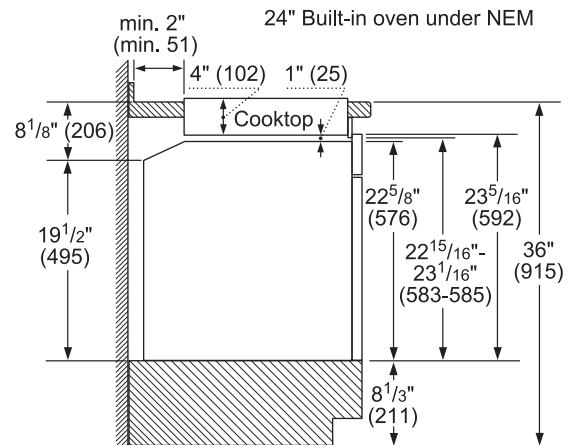

Notes: Dimensions based on standard countertop height (36" with 4 3/4" toe kick including base plate).

The built-in oven can be installed below the cooktop as long as there is at least 1" (25) of space between the bottom flat surface of the cooktop and the top of the oven.

Please allow at least 2" (51) from the countertop front edge to the edge of the cutout.

measurements in inches (mm)

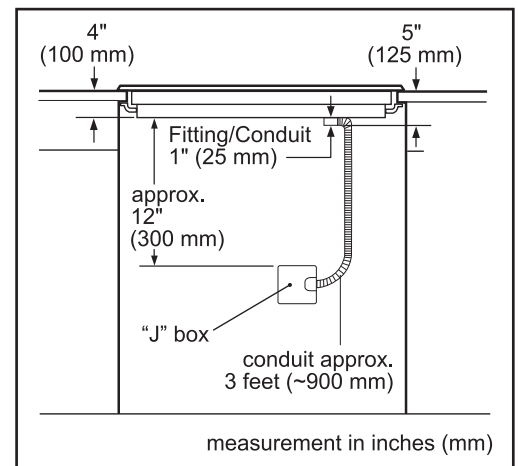

For help and assistance with Bosch accessories please visit: www.bosch-eshop.com/eshop/bosch/us or call 1-800-944-2904 Mon-Fri 5am to 6pm PST Sat 6am to 3pm PST

Notes: All height, width and depth dimensions are shown in inches. BSH reserves the absolute and unrestricted right to change product materials and specifications, at any time, without notice. Consult the product's installation instructions for final dimensional data and other details prior to making cutout. Applicable product warranty can be found in accompanying product literature or you may contact your account manager for further details.

Warranties: Bosch warrants that the Product is free from defects in materials and workmanship for a period of three hundred and sixty-five (365) days from the date of purchase. The foregoing timeline begins to run upon the date of purchase, and shall not be stalled, tolled, extended, or suspended, for any reason whatsoever. This Product is also warranted to be free from cosmetic defects in material and workmanship (such as scratches of stainless steel, paint/porcelain blemishes, chip, dents, or other damage) to the finish of the Product, for a period of thirty (30) days from the date of purchase or closing date for new construction. This cosmetic warranty excludes slight color variations due to inherent differences in painted and porcelain parts, as well as differences caused by kitchen lighting, product location, or other similar factors. This cosmetic warranty specifically excludes any display, floor, "As Is", or "B" stock appliances.

For more information on our entire line of products, go to www.bosch-home.com/us or call 1-800-944-2904

© BSH Home Appliances Corporation. All rights reserved. Bosch is a registered trademark of Robert Bosch GmbH.